

# PIPER

J-3

CUB

J-4

CUB COUPE

J-5

CUB CRUISER

PA-11

CUB SPECIAL

PA-12

SUPER CRUISER

PA-14

FAMILY CRUISER

PA-15

VAGABOND

PA-16

CLIPPER

PA-17

VAGABOND TRAINER

PA-18

SUPER CUB

PA-20

PACER

PA-22

TRI-PACER

PA-25

PAWNEE



# PIPER J-3 / PA-11

## Index for Piper Models

<i>Model</i>	<i>Page No.</i>
J-3/PA-11.....	5-2
PA-12/14 .....	5-11
J-4, J-5, PA-15/17, PA-16 .....	5-18
PA-18/18A .....	5-20
PA-20, PA-22 .....	5-39
PA-22 to PA-20 Conversions .....	5-52
PA-25 .....	5-55
Piper S.T.C.s, Conversions and Modifications .....	5-58
Piper Decal's .....	5-65

## Piper J-3/PA-11 Section Index

<i>Section</i>	<i>Page No.</i>
Manuals .....	45
Wings .....	45, 46
Fuselage.....	47
Control System .....	47-49
Chassis and Landing Gear .....	49
Brake System .....	49, 50
Cockpit Enclosure .....	50, 51
Cowling and Engine .....	51-53
Fuel System.....	53
Miscellaneous.....	53
Decal's .....	108
For batteries, brakes, propellers, wheels and windshields, look in the specific sections in this catalog.	

**All parts listed are for both J-3 and PA-11, unless otherwise specified.**

## Manuals



<i>Description</i>	<i>Part No.</i>
Piper Cub Aircraft Log .....	750-111
Piper Cub Engine Log .....	170-112
J-3 Owners Manual, C-65 .....	J3WM
J-3 Paint Scheme .....	J3PS
J-3 Parts Manual .....	J3PM
J-3 Service Manual .....	J3SM
J-3 Parts Manual, 1937-41 .....	J3EPM
PA-11 Parts Manual.....	11PM
PA-11 Paint Scheme.....	11PS
Service Aids, Bulletins, Letters and Memos for J-3 thru J-5 .....	PBLJ
Piper Inspection Report .....	230-3000

**PC 149**

## Wings

### J-3 and PA-11 Wings\*



J-3 Wing, Left Hand** .....	U15556-000	PA-11 Wing, Left Hand.....	10625-000UR
J-3 Wing, Right Hand** .....	U15556-001	PA-11 Wing, Right Hand .....	10625-001UR

Wings are built with UNIVAIR's one-piece, STC approved, formed aluminum wing ribs. Wings and other control surfaces come uncovered.

\* See "Crating Charge" prices at the beginning of our Price List.

\*\* STC/PMA approved (SA00054DE)

End Repetitive AD Inspections of Your Struts and Forks with Univair's New Sealed and Oiled Wing Struts with 5/8-inch Fork (comply with A.D. 99-01-05)



J-3 Front Strut .....	U85547-002	PA-11 Front Strut .....	U85554-002
J-3 Rear Strut .....	U85548-002	PA-11 Rear Strut .....	U85555-002
Struts include forks			

## Wings (continued)

<i>Description</i>	<i>Part No.</i>
Drag Strut "N" Brace Tube.....	U10112-007
Drag Strut Lock Bolt Plate .....	U10151-000
#2 and #3 Drag Strut, Drag Wire Pull.....	U10161-004
#4 Drag Strut, Drag Wire Pull .....	U10161-005
#1 Drag Strut, Drag Wire Pull .....	U10171-004
#5 Drag Strut, Drag Wire Pull .....	10171-005
Drag Wire Nipple .....	U10201-000
Tie Rod Clevis .....	U10221-000
Spar Butt Hinge Front Fitting.....	U10401-000
Pulley Housing (PA-11).....	U10552-000
Fuel Tank Cover Support (PA-11).....	10633-000
#2 Full Rib, Left Hand (PA-11) (10635-003) .....	U1224-000
#3 Drag Strut Pulley Bracket (PA-11) .....	U10644-000
#3 Full Rib, Left Hand (PA-11).....	10653-000
PA-11 Front Jury Strut Clamp.....	U10654-000
PA-11 Rear Jury Strut Clamp .....	10656-000
Left Hand Tip Rib .....	10742-002
Right Hand Tip Rib (10742-003) .....	U1202-01
#3 Full Rib, Right Hand (PA-11) .....	10907-000
Aileron Hinge Bracket.....	U10912-006
Bearing Block .....	U10921-000
False Spar Aileron Hinge Bracket Clamp .....	U10931-002
Rib Fairlead Retainer Plate (PA-11) .....	U11151-000
#1 Channel Brace .....	U12252-002
#3 Channel Brace .....	U12252-003
Wing Channel Brace.....	U12252-004
Wing Channel Brace.....	U12252-005
#2 Channel Brace .....	U12252-008
Butt Rib Leading Edge Attach Angle	12331-002
Rear Spar Jury Strut Fitting.....	U12581-000
Jury Strut Front Bracket (J-3) .....	U12601-000
J-3 Rear Jury Strut Clamp.....	U12611-000

## Wings (continued)

### J-3 & PA-11 High Strength, Heavy Duty Lift Strut Forks, FAA/PMA Approved Stainless Steel



1. Original Style 7/16 inch Fork (complies with AD 81-25-05)  
Part Number.....U13770-003
2. New 5/8 inch Rolled Threads, Heavy Duty Fork for use with Sealed Struts, complies with AD 93-10-06 (comes with AN316-10 nut)..U1600-01

### One-piece, Stamped Wing Ribs

For J-3 and PA-11 with metal spar (FAA/PMA)  
See page 101 in this catalog.

### For Wood Spar Wings-18 Gauge 3/4 inch Nail

Cement Coated  
Approximately 160/ounce.  
Available by the ounce.

Part number.....3/4-18NAIL

### J-3 Wood Spar Wing Assembly Video

This video provides detailed instruction relative to wing assembly demonstrating innovative functional tips and techniques along with building specialty assembly tools by noted Educator, Pilot and Mechanic Paul Babcock. Directed by R. Peter Carlson.



VHS.....PB3-WS  
DVD...PB3-WSDVD

**PC 399**

**All items on this page are Price Code 150 unless otherwise noted**

Price and availability subject to change without notice. Univair's Toll Free Sales: 1-888-433-5433

# PIPER J-3 / PA-11

## Wings (continued)

<i>Description</i>	<i>Part No.</i>
Nose Rib (12662-002) .....	U1200-02
Nose Rib, Left Hand at wing tank (PA-11) (12662-004) .....	U1200-08
Rear Spar Butt Fitting (Wood Spar J-3) .....	U12791-000
Front Spar Butt Fitting (Wood Spar J-3) .....	U12801-000
Aileron Outboard Rib, Left Hand (12902-000) .....	U1206-00
Aileron Outboard Rib, Right Hand (12902-001) .....	U1206-01
Aileron False Spar Reinforcement Gusset .....	13171-000
J-3 #2 and #3 Drag Strut Cable Guide Clamp .....	U13481-000
Rear Spar Butt Hinge Fitting .....	U14161-000
Rear Spar Lift Strut Fitting Assembly (J-3) .....	U14182-000
Front Spar Lift Strut Fitting Assembly (J-3) .....	U14192-000
#5 Drag Strut .....	U14222-000
#2 and #3 Drag Strut .....	U14222-002
Pulley Housing on Front Spar .....	U14261-000
Rear Spar Lift Strut Fitting Filler Block .....	U14271-000
Center Aileron Hinge Bracket Attach Angle, Left Hand .....	U14291-000
Center Aileron Hinge Bracket Attach Angle, Right Hand .....	U14291-001
Jury Strut Rear Fitting Attachment .....	U14361-002
Jury Strut Front Fitting Attachment .....	U14361-003
Jury Strut Rear Fitting and Filler Block .....	U14371-002
Jury Strut Front Fitting and Filler Block .....	U14371-003
Front Wing Spar, Left Hand .....	U14383-002
Front Wing Spar, Right Hand .....	U14383-003
Front Spar #1 Strut Reinforcement Angle .....	U14401-002
Front Spar #2 Strut Reinforcement Angle .....	U14401-003

### Wooden Wing Tip Bow FAA/PMA Approved

Part Number .....U453-126

### Metal Wing Spars for J-3 and PA-11 FAA/PMA Approved

Front, Left Hand .....	U14383-002
Front, Right Hand .....	U14383-003
Rear, Left Hand .....	U14453-002
Rear, Right Hand .....	U14453-003

**Note: Not interchangeable with wood spars.**

## Wings (continued)

### Jury Struts - FAA/PMA Approved

<b>A</b>	
<b>B</b>	
<b>C</b>	
<b>D</b>	

A Front Jury Strut, Left Hand (with pitot tube) .....	U12931-000
B Front Jury Strut, Right Hand .....	U12571-002
C Rear Jury Strut .....	U12571-003
D Jury Strut Spacer Tube (J-3) .....	U12591-000
D Jury Strut Spacer Tube (PA-11) .....	U12591-002

<i>Description</i>	<i>Part No.</i>
--------------------	-----------------

Front Spar #3 Strut Reinforcement Angle .....	U14401-004
Front Spar #5 Strut Reinforcement Angle .....	U14401-005
Rear Spar #2 Strut Reinforcement Angle .....	U14411-002
Rear Spar #3 Strut Reinforcement Angle .....	U14411-003
Rear Spar #5 Strut Reinforcement Angle .....	U14411-004
Rear Wing Spar, Left Hand .....	U14453-002
Rear Wing Spar, Right Hand .....	U14453-003
Lift Strut Front Spar Filler Block (J-3) .....	U14461-000
#1 Drag Strut Fairlead Clamp (J-3) .....	U14491-000
Aileron False Spar Brace .....	U14541-000
Aileron Pulley Attach Angle, Left Hand (14571-00) .....	U14571-001
Aileron Pulley Attach Angle, Right Hand .....	U14571-001
Aileron Horn Stop .....	U14581-000
Aileron Pulley Inboard 1/2 Left Hand Bracket .....	U14611-000
Aileron Pulley Inboard 1/2 Right Hand Bracket .....	U14611-001
#1, 2, 3 Wing Bay Drag Wire .....	U14941-006
#4 Wing Bay Drag Wire .....	U14941-007
Inboard False Spar, Left Hand .....	U15562-000
Inboard False Spar, Right Hand .....	U15562-001
Outboard False Spar, Left Hand .....	U15572-000
Outboard False Spar, Right Hand .....	U15572-001
Front Lift Strut Fitting Spacer .....	U15631-002
Rear Lift Strut Fitting Spacer .....	U15631-003
Nose Rib (at Strut point) (15712-000) .....	U1200-05
Wing Trailing Edge .....	U15773-000
Tip Nose Rib, Left Hand .....	U1216-00
Tip Nose Rib, Right Hand .....	U1216-01
Upper "N" Brace Tube .....	U16462-000
Lower "N" Brace Tube .....	U16472-000
Front Spar Bow Rear Fitting .....	U16551-000
Front Spar Bow Front Fitting .....	U16561-000
Rear Spar Bow Front Fitting .....	U16601-000
Rear Spar Bow Rear Fitting .....	U16611-000

## Wings (continued)

<i>Description</i>	<i>Part No.</i>
Short Fairlead Segment .....	U40071-000
Fairlead Snap Ring .....	U40081-000
Aileron Control Cable (in Wing) .....	U40123-003
Long Fairlead Segment .....	U40701-000
2-3/4-inch Pulley .....	U40991-000
Pulley Housing .....	U41291-000
Cable Fairlead .....	U42911-000
Lower Front Fairing (J-3 Friese type) .....	U60361-000
J-3 Fairing .....	U60371-000
Lower Rear Root Fairing, Right Hand (J-3 Friese type) .....	U60371-001
Teardrop Reinforcement Patch (J-3) .....	U60481-000
Wing Pulley Cover Cup Grommet .....	U60671-000
Top Root Fairing, Left Hand (Wood Spar J-3 Friese) .....	U60711-000
Top Root Fairing, Right Hand (Wood Spar J-3 Friese) .....	U60711-001
Wing Pulley Fairing Cover Cup .....	U60752-000
#2 and #3 Drag Strut Cable Guide Clamp .....	U80002-027
Jury Strut Attach Lug .....	U80002-041
Butt Fitting Attach Washer .....	80022-031
Attaching Washer .....	U80122-011
Inspection Ring...85012-078 or <b>PC 399</b> 483-15	
Air Speed Tubing Grommet .....	80122-051
Wing Drain Grommet .....	U80122-053
1-3/4-inch Pulley .....	U80421-000
Rectangular Inspection Plate Grommet .....	U80541-002
Tie Rod Clevis Square Washer .....	U81102-003
Wing Tip Grommet .....	81232-015
Aileron Control Attach Link (PA-11) .....	U81262-036
Lift Strut Clevis Bolt .....	U82141-000
Rectangular Inspection Cover .....	82461-000
Pulley Bracket Spacer Bushing .....	U82732-024

### J-3 and PA-11 Wing Leading Edge Skins

#### For Metal Spar Wings FAA/PMA Approved

PA-11 Inboard, Left Hand .....	U10630-000
PA-11 Inboard-Center, Left Hand .....	U10631-000
J-3/PA-11 Outboard, Left Hand or Right Hand .....	U13072-005
J-3 Inboard, Left Hand .....	U15472-000
J-3/PA-11 Inboard, Right Hand .....	U15472-001
J-3/PA-11 Center, Left Hand .....	U15482-000
J-3/PA-11 Center, Right Hand .....	U15482-001
J-3/PA-11 Tip, Left Hand .....	U15723-000
J-3/PA-11 Tip, Right Hand .....	U15723-001

### J-3 Wing Leading Edge Cover (Wood Spar Wing)

Formed Leading Edge Blanks .....CSI-1035  
(3 pieces required per wing;  
12-by-72 inches; priced each)

# PIPER J-3 / PA-11

## Fuselage

<i>Description</i>	<i>Part No.</i>
Rear Window Channel, Right Hand ..	U10058-000
Brake Unit Support (PA-11) .....	10134-000
Stabilizer Yoke Insp. Grommet (PA-11)	U10292-000
Tail Inspection Grommet .....	U10293-000
Windshield Front Strip (PA-11) .....	U10793-000
Windshield Rear Strip (PA-11).....	10794-000
Stringer Attach Clip .....	U20391-000
Stabilizer Screw Upper Bearing .....	20491-003
Tail Skid Front U Fitting .....	U20631-000
Torque Tube Rear Bracket .....	U20751-000
Rear Aileron Pulley Housing Plate, Left Hand (PA-11) .....	20951-000
Rear Aileron Pulley Housing Plate, Right Hand (PA-11) .....	20951-001
Front Aileron Pulley Housing Plate, Left Hand (PA-11) .....	U20961-000
Front Aileron Pulley Housing Plate, Right Hand (PA-11) .....	U20961-001
Stabilizer Rear Support .....	U21161-000
Front Landing Gear Fitting .....	U21272-002
Wing Hinge Front Fitting .....	U21431-000
Stabilizer Adjustment Crank Bracket, Left Hand .....	J21571-000
Stabilizer Adjustment Crank Bracket, Right Hand (21571-001) .....	J21571-000
Front Fairing Tube .....	U21872-000
J-3 Fuselage Cowl (U22443-000) .....	U23993-000
J-3 Front Windshield Strip .....	U23942-000
J-3 Rear Windshield Strip .....	U23952-000
Floorboard Attach Fitting .....	24101-000
Rudder Pedal and Floorboard Front Attach Fitting .....	U24121-002
Floorboard Attach Fitting .....	U21421-003
Door Plunger Assembly .....	U50131-000
Latch Link Assembly .....	50192-000
Yoke Inspection Cover, LH .....	U60571-000
Yoke Inspection Cover, RH .....	U60571-001
Tail Inspection Panel, Left Hand ...	U60742-000
Tail Inspection Panel, Right Hand ..	U60742-001
Landing Gear and Lift Strut Bushing	U80012-063
Stabilizer Screw Lower Bearing .....	80022-020
Tail Tie Rod Plate (J-3) .....	80292-015
Rectangular Inspection Plate Grommet .....	U80541-002
Tail Skid Front Fitting Plate .....	U81102-005
Front Landing Gear Fitting Gusset ..	81272-015
Front Seat Rear Attach Clamp .....	U81332-009
Engine Mount and Bulkhead Bushing ..	82341-002

## J-3 Top Deck Superstructure

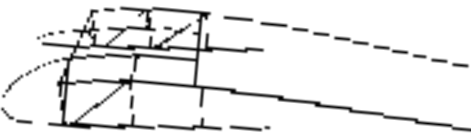

J-3 Superstructure.....U24096-002

**All parts listed are for both J-3 and PA-11, unless otherwise specified.**

## Reinforcements

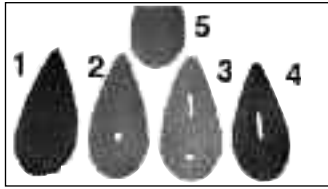

- |         |            |
|---------|------------|
| 1 ..... | U60481-000 |
| 2 ..... | U60863-005 |
| 3 ..... | U60863-002 |
| 4 ..... | U60863-003 |
| 5 ..... | U60863-009 |

For your Covering and Finishing needs, see the Paint, Dope and Fabric section in this catalog. UNIVAIR stocks Tempo, Poly Fiber, Randolph, Ceconite, and other fine lines.

## Common Piper Grommets

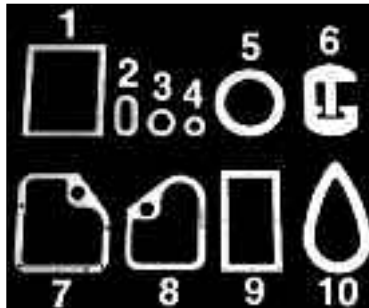

For Drain Grommets, see Paint, Dope and Fabric section in this catalog.

- |          |                               |   |
|----------|-------------------------------|---|
| 1 .....  | Grommet, Tail .....           | U10292-000                                      |
| 2 .....  | Grommet .....                 | U10984-000                                      |
| 3 .....  | Grommet .....                 | U85012-049                                      |
| 4 .....  | Grommet .....                 | 80122-051                                       |
| 5 .....  | Grommet, Inspection Plate ... | U85012-078                                      |
| 6 .....  | Grommet, Strut .....          | U15761-000                                      |
| 7 .....  | Grommet, Tail .....           | U64834-000<br>(used on PA-25 and later PA-18's) |
| 8 .....  | Grommet, Tail .....           | U10293-000                                      |
| 9 .....  | Grommet, Cover .....          | U80541-002                                      |
| 10 ..... | Grommet, Pulley Cover .....   | U60671-000                                      |

## Control System

<i>Description</i>	<i>Part No.</i>
Stabilizer Tube Yoke Link (J-3), SN 2740-4132 (40771-000) .....	U14180-002
Elevator Cable Attach Link, Rear-Upper (PA-11) .....	U10449-000
Throttle Lever Knob (PA-11) .....	10911-000
Stabilizer Indicator Cover Plate (PA-11) .....	U10936-000
Bungee Spring (PA-11) .....	U10940-000
Torque Tube Bearing .....	21811-003
Short Fairlead Segment .....	U40071-000
Fairlead Ring .....	U40081-000
Fin Tie Rod Clevis Washer .....	U40131-000
Control Stick .....	U40231-000
Control Stick Connect .....	U40261-000
Bellcrank .....	U40663-004
Tailbrace Wire Clevis, Upper (40531-02) .....	U61341-002
Tailbrace Wire Clevis (40521-05) ..	U61341-003
Tailbrace Wire Clevis, Lower (40521-06) .....	U61341-004
Clevis (40531-00) .....	U61340-000
Stabilizer Adjustment Idler Yoke ...	U40651-000
Long Fairlead Segment .....	U40701-000

## Tailbrace Wires - FAA/PMA Approved



- Round type to comply with A.D. 60-01-07.  
Stainless Steel Wires & Clevis
- |                                 |   |
|---------------------------------|---|
| Upper Wire Assembly .....       | U10555-002  |
| Lower Wire Assembly .....       | U10556-002  |
| Original Installation Kit ..... | 10555-KIT<br>(for first time round wires are installed) |

## J-3 and PA-11 Control Cables - FAA/PMA Approved



<i>Description</i>	<i>Qty. Req'd.</i>	<i>Galvanized Steel Part No.</i>	<i>Stainless Steel Part No.</i>
PA-11 Rudder Cable .....	(2) .....	U10865-000	U10865-005
PA-11 Elevator to Upper Horn .....	(1) .....	U10869-000	U10869-003
PA-11 Elevator to Lower Horn .....	(1) .....	U10870-000	
J-3 Rudder Cable .....	(2) .....	U40123-002	U40123-002S
J-3 Aileron Control .....	(2) .....	U40123-003	U40123-003S
J-3 Aileron on Lift Strut, SN 1-8277) ..	(2) .....	U40123-004	U40123-004S
J-3 Elevator to Lower Horn .....	(1) .....	U40123-005	U40123-005S
J-3 Elevator to Upper Horn .....	(1) .....	U40123-006	U40123-006S
PA-11 Aileron on Lift Strut .....	(2) .....	U40123-028	U40123-028S
J-3 Aileron on Lift Strut, SN 8278 and up	(2) .....	U40123-034	U40123-034S
J-3, PA-11 Trim Cable .....	(1) .....	U41671-002	41671-008
Piper Special Turnbuckle Fork .....		U461-132	
Turnbuckle Assembly .....		U42722-000	

**All items on this page are Price Code 150 unless otherwise noted**

Price and availability subject to change without notice. Univair's Toll Free Sales: 1-888-433-5433

# PIPER J-3 / PA-11

## Control System (continued)

<i>Description</i>	<i>Part No.</i>
Stabilizer Cable Guide Rubbing Block.....	U40721-000
Stabilizer Guide Rubbing Plate .....	40731-000
Stabilizer Adjustment Link Tube (40771-000) .....	U14180-002
Stabilizer Indicator Wire Pulley Housing .....	40821-003
Rudder Pedal, Left Hand .....	U40842-004
Rudder Pedal, Right Hand .....	U40842-005
Rudder Pedal Spring .....	U40941-000
2-3/4-inch Pulley.....	U40991-000
Upper Tailbrace Wire .....	U41031-002
Lower Tailbrace Wire .....	U41031-003
Tie Rod Nipple.....	U41051-000
Trim Crank Plate .....	U41101-000
Stabilizer Crank Assembly .....	41111-002
Stabilizer Indicator .....	U41121-000
Spring (for Escutcheon) .....	U41151-000
Stabilizer Adjustment Crank Pulley .....	U41171-000
Torque Tube Bearing Shim .....	41371-005
Wing Pulley Housing on Strut .....	U41421-000
Throttle Lever .....	U41491-000
Throttle Lever Connecting Link .....	41551-000
Stabilizer Screw Pulley Key .....	U41631-000
Stabilizer Indicator Wire .....	U42664-003
Stabilizer Adjustment Yoke.....	U42692-000
Control Stick Lower Stub .....	42792-000
Control Stick Assembly .....	42812-000
Rear Control Stick (PA-11).....	42812-002
Stabilizer Indicator Spring - J-3 SN 13982 and up, and all PA-11's.....	42891-000
Cable Fairlead .....	U42911-000
Stabilizer Adjustment Screw (42961-00).....	U42961-002
Stabilizer Screw Pulley .....	U43061-000
Fin Leading Edge Fairing .....	U60602-000
Cable Fitting .....	U70371-000
Stabilizer Indicator Wire Attach Clamp.....	U80002-015
Wing Aileron Pulley Bushing .....	U80012-003
Fuselage Aileron Pulley Bushing .....	80012-004
Stabilizer Tie Rod Clevis Bushing .....	80012-006
Control Surface Bushing, Long .....	U80022-044
Control Surface Bushing, Short .....	U80022-045
Washer.....	80122-007
Clevis Pin Washer .....	80122-086
Stabilizer Link Attach Washer .....	U80122-024
Stabilizer Screw Pulley Washer.....	80122-041
Stabilizer Rear Liner Tube (80132-010) .....	U86062-079
Stabilizer Front Liner Tube, SN 4133 and up (80132-011) .....	U86062-080
Attaching Clamp .....	80222-003
1-3/4-inch Pulley.....	U80421-000
Square Tie Rod Clevis Washer .....	U81102-002
Friction Lug.....	U81172-020
Attach Link .....	U81262-008
Stabilizer Idler Yoke Link.....	81322-003
Stabilizer Screw Pulley Washer.....	81342-005
Elevator Bellcrank to Cable Link Washer for J-3.....	81342-019

### FAA/PMA Approved Fairleads

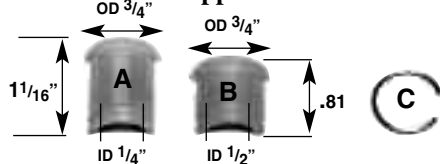

A. Long Fairlead Segment .....	U40701-000
B. Short Fairlead Segment .....	U40071-000
C. Snap Ring .....	U40081-000

Each segment sold separately.



### Ailerons - FAA/PMA Approved (uncovered; for SN 2625 and up)

Left Hand Aileron.....	U42585-000
Right Hand Aileron .....	U42585-001

### Tail Surfaces for J-3 (SN 4133 and up) and all PA-11's

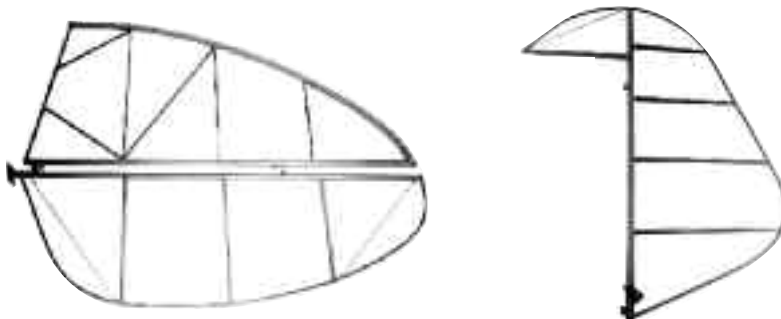

Left Hand or Right Hand Elevator, uncovered .....	40572-000
Vertical Fin, uncovered.....	U40592-000
Rudder, uncovered.....	U41313-000
Left Hand or Right Hand Stabilizer, uncovered.....	U40643-000
Rudder Attachment Hardware.....	PSK-1
Elevator Attachment Hardware .....	PSK-2
Steel Strobe Light Bracket (for top of rudder)(FAA Field Approval Required).....	U15722-002

### FAA/PMA Approved Piper Pulleys

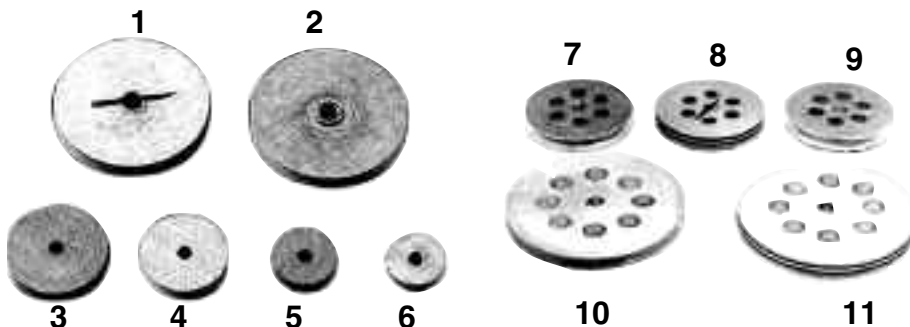

<i>Fig.</i>	<i>Part Number</i>	<i>Description</i>	<i>O.D.</i>	<i>I.D.</i>
1	U41171-000	Pulley, trimcrank with bushing (fiber)	2-3/4 in.	3/8 in.
1a	U40991-000	Pulley (no slot)	2-3/4 in.	3/8 in.
2	U41001-008	Pulley, with bearing (fiber) (41001-010)	2-3/4 in.	5/16 in.
3	U80421-000	Pulley (fiber)	1-3/4 in.	1/4 in.
4	U481-609	Pulley (fiber)	1-1/2 in.	1/4 in.
5	U11200-000	Pulley (fiber)	1-1/8 in.	1/4 in.
6	U43001-000	Pulley (fiber)	1 in.	1/4 in.
7	U43061-000	Pulley, stabilizer screw (aluminum)	2-3/4 in.	3/8 in.
8	U12983-000	Pulley, double groove (aluminum)	2-3/4 in.	3/8 in.
9	U10080-000	Pulley, trimcrank (aluminum)	2-3/4 in.	3/8 in.
10	U11008-000	Pulley, adjustment screw (aluminum), single groove	4 in.	3/8 in.
11	U12982-000	Pulley, adjustment screw (aluminum), double groove	4 in.	3/8 in.

### Liner Tubes — FAA/PMA Approved

Link Assembly Liner Tube (upper tube in picture) (80132-011) .....	U86062-080
Rear Liner Tube (lower tube in picture) (80132-010) .....	U86062-079

*All parts listed are for both J-3 and PA-11, unless otherwise specified.*

# PIPER J-3 / PA-11

## Control System (continued)

<i>Description</i>	<i>Part No.</i>
Throttle Friction Washer .....	U81342-020
Fuselage Aileron Pulley Washer ....	U 81342-042
Aileron Cable Attach Link (J-3) .....	81352-011
Bungee Pulley Housing (PA-11).....	U81381-000
Pulley Locking Pin .....	81761-004
Stabilizer Crank Lock Pin.....	81761-011
Attach Washer (85012-006) <b>PC 580</b>	AN940-10

All parts listed are for both J-3 and PA-11, unless otherwise specified.

## Chassis and Landing Gear

<i>Description</i>	<i>Part No.</i>
Anchor Pin (750-006) .....	<b>PC 670</b> A20-54
Felt Retainer Washer (750-010).....	A56-4
Lock Side Ring (750-025) .....	A85-118
Felt Retainer Ring (750-026).....	A85-218
Cone Bearing (750-063) .....	<b>PC 570</b> 08125
Bearing Cup (750-064) .....	<b>PC 570</b> 08231
Felt Retainer (750-065).....	<b>PC 670</b> B227-52
Rudder Arm (750-330).....	<b>PC 690</b> 1140
Master Cylinder Diaphragm (2844).....	U750-384
Diaphragm Pad (750-385) .....	<b>PC 690</b> 2003-1
Master Cylinder Spring (750-386).....	1256
Tailwheel Bronze Bushing (750-722).....	1800
Tailwheel Hub Assembly (750-752).....	1967
Brake Line (copper) .....	U10034-000
PA-11 Shock Cord Cover.....	U10566-000
PA-11 Shock Cord Cover End Plate ..	U10567-000
Axle Nut 1 1/4 in. ....	U30491-000
Tailwheel Spring .....	U30512-002
Tailwheel Spring .....	U30512-003
Tailwheel Spring .....	U30512-004
Tailwheel Spring .....	U30522-000
Tailwheel Spring Clamp (J-3, SN 10399 and up).....	U30531-000

### J-3 Shock Cord Cover (original vinyl)



J-3 Shock Cord Cover.....31073-000

### Stabilizer Yoke and Adjustment Screw FAA/PMA Approved



Yoke .....U42692-000  
Adjustment Screw .....U42961-102

## Chassis and Landing Gear (continued)

<i>Description</i>	<i>Part No.</i>
Flex Brake Line .....	U71061-004
Landing Gear Bushing, 5/16 in. (J-3).....	80022-026
Landing Gear Bushing, 3/8 in. (J-3) ..	U80022-063
Washer .....	U80122-041
Step.....	U81903-002
J-3 & PA-11 Complete Tailwheel Spring Assembly .....	J3TWSHR

### Landing Gear – FAA/PMA Approved



Left Gear, uncovered .....U10033-006  
Right Gear, uncovered .....U10033-005  
For Heavy Duty Gears, see LANDING GEAR  
in PA-18 section of this catalog.

### FAA/PMA Approved Piper Hub Caps Stamped Metal - Not Plastic!

#### Raised lettering



**Steel**  
For original 8.00X4  
Goodrich Wheels  
Stamped with "CUB"  
.....U31702-000  
Plain .....U31702-002  
(Primed Only)



**Aluminum**  
For 6.00X6 Cleveland  
Conversion Wheels  
Stamped with "CUB"  
.....U1680-00  
Plain .....U1680-02  
(Bare Aluminum)

**PC 150**

### Cub-Mask



Fits over the raised letters on the above hub caps and  
makes the job of painting cleaner and neater.

Cub-mask.....**PC 350**.....CUB-MASK

### Shock Cords – FAA/PMA Approved



J-3, SN 1-8277 (4 req'd) (1174) .....U30462-002  
J-3, SN 8278 and up (4 required) (1280HD)  
..... U31322-005

**PC 150**

To insure the proper selection of parts, we  
suggest that you use your J-3 and PA-11 parts  
manual with this catalog.

## Chassis and Landing Gear (continued)

### Tailwheel Spring Assembly FAA/PMA Approved



J-3 and PA-11 .....J3TWSHR

### Landing Gear Parts FAA/PMA Approved



### Cabane Vee Assembly

J-3 SN 8278\* and up, and  
all PA-11 SN's .....U30602-006  
\* Required on J-3's upgraded to 1220 gross weight.

### Short Shock Strut

J-3 SN 1-8277 .....U30442-006  
J-3 SN 8278 and up, and  
all PA-11 SN's .....U31392-000

### Long Shock Strut

J-3 SN 1-8277 .....U30562-000  
J-3 SN 8278 and up .....U31382-000  
PA-11 .....U10537-002\*

### Shock Strut Assembly

J-3 SN 8278 and up .....U31423-000  
PA-11 .....U10536-002  
\*U10537-002 Replaces 10537-000

## Brake System

<i>Description</i>	<i>Part No.</i>
Master Cylinder, Left Hand (451-700) .....	<b>PC 690</b> 1248H
Master Cylinder, Right Hand (451-701) .....	<b>PC 690</b> 1260H
Brake Assembly (surplus) (451-702) .....	<b>PC 670</b> D2-113
Brake Bleeder Fitting Assembly (451-771) .....	<b>PC 670</b> B57-240
J-3 45° Elbow (460-663) .....	<b>PC 525</b> 3350x2
Retaining Spring (750-029) .....	<b>PC 670</b> B21-35
Brake Block (750-033) .....	B27-59-1
Inner Fairing (750-035) .....	B51-72
Brake Frame (J-3 SN 1999-4411) .....	<b>PC 150</b> 750-038
Brake Frame (750-039).....	<b>PC 670</b> D12-101
Brake Frame Flange (750-041) .....	<b>PC 670</b> D15-25
Control Rod (J-3) .....	<b>PC 150</b> 750-049
Brake Piston Rod (J-3) .....	<b>PC 150</b> 750-051
Master Cylinder Piston (750-295) .....	<b>PC 690</b> 1383

**All items on this page are Price Code 150 unless otherwise noted**

Price and availability subject to change without notice. Univair's Toll Free Sales: 1-888-433-5433

# PIPER J-3 / PA-11

## Brake System (continued)

<i>Description</i>	<i>Part No.</i>
Washer.....	80122-007
Attaching Washer.....	U80122-011
Attaching Link.....	U81262-008
Front Rudder Pedal Attach Washer, Upper.....	85012-004
Front Rudder Pedal Attach Washer, Lower.....	85012-005

## Master Cylinder

**Detail Replacement Parts Available. See Tire, Wheel, and Brake Section.**



Left Hand (new).....	1248H
Right Hand (new).....	1260H

**PC 690**

## Cleveland Wheel and Brake Kit

Convert from your Goodrich Wheels and Brakes to the new Cleveland Wheels and Brakes. Uses the 6.00 x 6 tires. FAA 337 or STC approval required for installation.

Request STC SA11RM-1.25 when you purchase the above kit and it is available at no charge.



Cleveland Conversion Kit.....**PC 660**.....199-07100

Installation may require:

Lines (2 each).....	<b>PC 150</b> .....U60703-002
Elbows (2 each) (558-819).....	<b>PC 525</b> ..... 502X4
Elbows (2 each) (460-677).....	<b>PC 525</b> ..... 402X4
STC, for 1-1/4-inch axle.....	STC-SA11RM-1.25
Stamped Metal "CUB" Hubcaps: 6.00X6 for Cleveland Conversion wheels .....	<b>PC 150</b> .....U1680-00

Cub-Mask--Fits over the raised letters on the above hub caps and makes the job of painting cleaner and neater.



Cub-Mask.....**PC 350**.....CUB-MASK

## Brake Lines FAA/PMA Approved

From brake master cylinder to copper line on gear vee.



Brake Line.....U71061-004

## Brake Pedals



J-3, Left.....	U41602-002
J-3, Right.....	U41602-003
PA-11, Left.....	10734-000
PA-11, Right.....	10734-001

## Goodrich Brake Drum (Hayes)



Drum (750-894).....	<b>PC 670</b> .....B13-4
Rivets (6 required) (750-895).....	<b>PC 580</b> .....AN441-6-6P

## Goodrich Brake Assembly Parts for all Pipers with 8.00 x 4 wheels



### While Supply Lasts!

Brake Block (750-033).....	B27-59-1
Spring (750-029).....	B21-35
Shield (750-093).....	A72-30

**PC 670**

## Grove 800 x 4 Disk Brake Conversion (Goodrich wheels and brakes only)



### New FAA/PMA Approved Disc Brake Conversion

- Maintain your classic look
- Use your existing wheels, tires and tubes
- Use your existing master cylinder and brake lines
- Easy Installation - all parts & special tools included

Grove Brake Conversion.....76000

## Description

## Part No.

Brake Pedal Block.....	U41521-000
Brake Pedal Block.....	41531-000
Brake Pedal Stop Block.....	U41561-000
Brake Pedal Tie Rod.....	U41581-004
Brake Line Assembly (J-3 SN16588 and up, and all PA-11 SN's).....	U71061-004

## Cockpit Enclosure

Top and Side of Door Enclosure Rubber Moulding, priced per foot (PA-11).....	187-610
Cowl Clip (454-888).....	<b>PC 580</b> AN415-2
Non-Recording Tachometer Shaft (486-565).....	<b>PC 635</b> TACH-34NR
Rear Window Trim Strip, Left Hand.....	U10044-000
Airspeed Tube.....	10554-000
Window Attach Trim Strip, Right Hand (PA-11).....	10668-000
Rear Floorboard (PA-11).....	10799-000
Aileron Pulley Housing (J-3 SN 8278 and up, and all PA-11 SN's).....	U50042-000
Inside Channel Cover.....	U50301-000
Canvas Seat Back, Front Seat (J-3).....	50982-000
Door Weatherstrip.....	52841-000
Windshield Strip, Left Hand (J-3).....	53922-017
Top Deck Rear Trimstrip.....	U54581-000
Wing Root Fairing, Left Hand.....	U60803-000
Wing Root Fairing, Right Hand.....	U60803-001
Wing Butt Rear Fairing.....	U60882-000
Safety Belt Connector Link.....	U80002-042
Primer Pump Spacer Bushing.....	80012-065
Attaching Clamp.....	U80222-003
Attaching Link.....	U81262-008
Window Attaching Washer.....	U81342-045

## Windows and Windshields

J-3 Windshield.....	10009-000
J-3 Front Window, L/H.....	10041-000
J-3 Rear Window, Left Hand.....	10046-000
J-3 Rear Window, Right Hand.....	10047-000
J-3/PA-11 Door Window.....	10051-000
J-3/PA-11 Top Deck Skylight.....	10056-000
J-3/PA-11 Sliding Window Assembly.....	U50761-000
J-3/PA-11 Sliding Window, Glass Only.....	U50761-002
PA-11 Rear Window.....	10545-000
PA-11 Windshield.....	10673-000

**NOTE: The above windows are clear. For a listing of stocked tinted windows, please refer to the J-3 and PA-11 listings in our Window & Windshield section.**

**All parts listed are for both J-3 and PA-11, unless otherwise specified.**

**All items on this page are Price Code 150 unless otherwise noted**

Price and availability subject to change without notice. Univair's Toll Free Sales: 1-888-433-5433

# PIPER J-3 / PA-11

## Cockpit Enclosure (continued) J-3 Blank Instrument Panel Original Shape, Aluminum FAA/PMA Approved



Arrange your instrument panel to suit your specific needs!

J-3 Blank Instrument Panel.....U54703-000

### Oil Pressure Hose FAA/PMA Approved



Oil Pressure Hose.....U71061-000

## Cowling and Engine

### Engine Mount FAA/PMA Approved

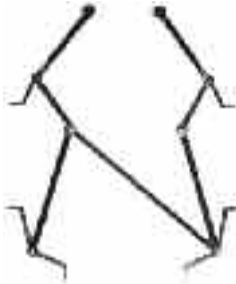

J-3 Mount .....U71163-000\*  
PA-11 Mount C90 .....U10576-000

\* Part number U71163-000 is approved to accommodate the O-200 engine, and it is the required mount for the O-200 engine installation STC-SA107RM.

### New Stainless Steel Exhaust Gaskets for Continental Engines



**2 required  
per port**

Blo-proof Gaskets.....**PC 201**..SA632837

## Cowling and Engine (continued)

<i>Description</i>	<i>Part No.</i>
J-3 Cowl Clip (454-888).....	<b>PC 580</b> AN415-2
J-3 Fuel Line Nipple (460-656)	<b>PC 525</b> 3326X4
J-3 Fuel Line Elbow (460-659)	<b>PC 525</b> 352X6
J-3 Fuel Line Elbow (460-661)	3400X4
J-3 Inverted Nut (460-665)	105X2
Jet Primer (straight type J-3) (468-340)	U31197-000
Felt Washer	494-005
Elbow (J-3)	496-289
Muff Shroud to Heater Hose (PA-11)	10525-003
PA-11 Engine Mount	U10576-000
Exhaust Stack, Right Hand (PA-11)	10760-000
Muffler Shroud (PA-11)	U10762-000
Exhaust Shroud, Left Hand Upper (PA-11)	U10764-000
PA-11 Top Cowl	U10808-000
PA-11 Bottom Cowl	U10809-000
Rear Side Baffle, Left Hand (PA-11)	10830-000
Rear Side Baffle, Right Hand (PA-11)	10832-000
Front Side Baffle, Left Hand (PA-11)	10835-000
Lower Exhaust Shroud, Left Hand (PA-11)	U10843-000
Lower Exhaust Shroud, Right Hand (PA-11)	U10845-000
Lower Exhaust Shroud, Right Hand (PA-11)	U10846-000
Baffle Hanger Support (PA-11)	U10920-000
Inner Cylinder Baffle—Inner (PA-11)	10922-000
Inner Cylinder Baffle—Outer (PA-11)	U10923-000
J-3 Throttle Control	U12694-002
Cabin Heater Control Bracket (J-3)	70211-000
Cable Fitting	U70371-000
Muffler Stack Connecting Clamp Assembly (J-3)	U70591-002
Engine Mount Throttle Control Clamp	70801-000
J-3 Baffle Assembly, Left Hand	U70873-002
J-3 Baffle Assembly, Right Hand	U70873-003
J-3 Muffler Shroud	U70963-000
J-3 Engine Mount (Continental 65 hp.)	U71163-000
Slide Clip (J-3)	U71261-000
Baffle Tie Rod (PA-11)	71451-003
Fuel Strainer Bracket Assembly	71991-000
Engine Baffle Bracket	U72201-000
Air Intake (J-3)	U72522-000
Nose Cowl Bracket, R/H (J-3) Continental A-65	U72571-000
Nose Cowl Bracket, L/H (J-3)	U72651-000
Engine Breather Line Clamp	72941-000
Nose Cowl Bracket, Left Hand (J-3 Franklin 65 hp.)	72951-000
Nose Cowl Bracket, Right Hand (J-3 Franklin 65 hp.)	72961-000

## Cowling and Engine (continued) All-Aluminum Cowling for J-3 FAA/PMA Approved

Firewall J-3	U22453-000
J-3 Fuselage Cowl	U23993-000
J-3 Top Cowl, Front Piece Only	U74353-000
J-3 Bottom Cowl, Front Piece Only	U74334-000
Cowl Fastening Pin	<b>PC 580</b> ... AN415-2

### Top Cowl for J-3 FAA/PMA Approved



Part Number .....U72543-000

### All-Aluminum Bottom Cowl for Continental Powered J-3 (SN 10399 & UP)

FAA/PMA Approved



Part Number .....U74613-000

### J-3 Fuselage Cowl

FAA/PMA Approved



Fuselage Cowl	U23993-000
Forward Windshield Strip	U23942-000
Rear Windshield Strip	U23952-000

### Air Induction "Y"

FAA/PMA Approved

Part Number.....U72522-000



### All Metal PA-11 Cowling FAA/PMA Approved



PA-11 Nose Cowl for screw fasteners	U10802-000
PA-11 Nose Cowl for Lion fasteners	U10802-005
PA-11 Top Cowl	U10808-000
PA-11 Bottom Cowl	U10809-000
PA-11 Fuselage Cowl	U10789-000
PA-11 Side Cowl, Left Hand	U10810-000
PA-11 Side Cowl, Right Hand	U10810-001

**All items on this page are Price Code 150 unless otherwise noted**

Price and availability subject to change without notice. Univair's Toll Free Sales: 1-888-433-5433

# PIPER J-3 / PA-11

## Cowling and Engine (continued)

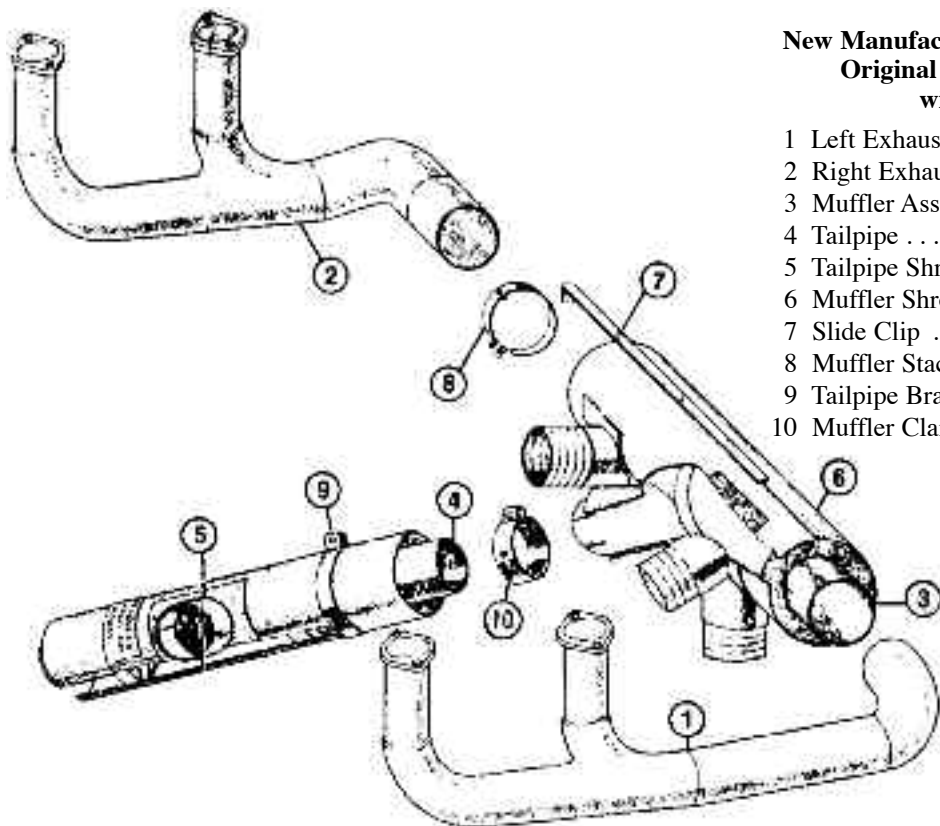

### J-3 Exhaust System

**New Manufactured, FAA/PMA Approved, Stainless Steel  
Original Design, Exhaust Headers and Muffler  
with Safety Bail already installed**

- 1 Left Exhaust Stack .....U71082-000
- 2 Right Exhaust Stack .....U70671-000
- 3 Muffler Assembly, less shroud .....U71053-002
- 4 Tailpipe .....U74501-000
- 5 Tailpipe Shroud .....U70912-000
- 6 Muffler Shroud .....U70963-000
- 7 Slide Clip .....U71261-000
- 8 Muffler Stack Connecting Clamp (2 req'd) ..U70591-002
- 9 Tailpipe Brace Clamp .....U80002-022
- 10 Muffler Clamp .....U72691-000

## Cowling and Engine (continued) Carburetor Air Box for 4 Cylinder Continental Engines FAA/PMA Approved



- Carburetor Air Box for: C-75, C-85, C-90,  
engines ..... UA50256
- Carburetor Air Box for: A-65  
engines.....UA50495
- Air Filter only (40599) ..... **PC 275** 600314
- Gasket ..... 652142

**PC 201**

### Structural Repairs?

See the  
**Raw Materials section of this  
catalog for 4130 Steel Tubing**

## Cowling and Engine (continued)

<i>Description</i>	<i>Part No.</i>
Exhaust Stack, Left Hand (J-3Franklin 65 hp.) .....	73083-000
Exhaust Stack, Right Hand (J-3 Franklin 65 hp.) .....	73133-000
Cold Air Intake Cover Plate (J-3) ....	U73951-000
J-3 Engine Mount (Lycoming 50-65 hp.) ..	74234-000
Motor Mount Cowl Bracket, Left Hand (J-3 Lycoming 65 hp.) .....	74261-000
Motor Mount Cowl Bracket, Right Hand (J-3 Lycoming 65 hp.) .....	74271-000
J-3 Bottom Cowl, SN 10339 and up ..	U74613-000
Throttle Control Cable Clamp (J-3)	U80002-003
Tailpipe Brace Attach Clamp (PA-11) .....	U80002-020
Tailpipe Brace Attach Clamp (J-3) ..	U80002-022
Cable Guide Clamp (PA-11) .....	U80002-027
Carburetor Heat Control Cable Clamp (J-3).....	U80032-034
Filler Neck Washer (J-3) .....	U80122-048
Fiber Washer .....	81342-022
Crankcase Breather Tube.....	U84332-000
Tachometer Adapter Attach Washer (PA-11) .....	85012-014
Continental Propeller Front Plate <b>PC 201</b> ..	10351

## Cowling and Engine (continued)

### All-Aluminum J-3 "Eyebrow" Baffles FAA/PMA Approved



- Left Side Baffle.....U70873-002
- Right Side Baffle .....U70873-003

### FAA/PMA Approved J-3 Eyebrow Fairing Bracket



- Part Number .....U72201-000

**All parts listed are for both J-3 and  
PA-11, unless otherwise specified.**

# PIPER J-3 / PA-11

## Cowling and Engine (continued)

FAA/PMA Approved

### Continental Powered J-3 Cowling Brackets

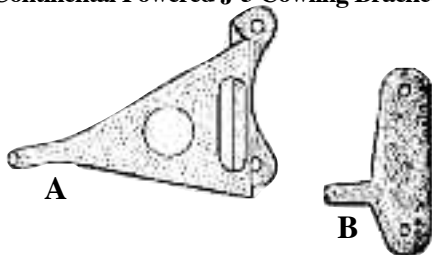

- A Cowl Bracket, Right Hand .....U72571-000  
 B Cowl Bracket, Left Hand .....U72651-000

### Continental Engine Mount Bushings (8 required per installation)



- Cont. Engine Mount Bushings.....22387  
**PC 201**

### Skull Cap Spinner



- Small Skull Cap Spinner  
and Bracket .....**PC 299** SM-SPIN-ASY  
 Small Skull Cap Spinner  
.....**PC 115** U0450279  
 Spinner Bracket.....**PC 115** U0450281  
 Note: May not fit all taper shaft installations.

### Propeller Bolt Kits

- CM Series Flange Shaft .....B4622-9  
 CM Series Taper Shaft .....B4622-42  
**PC231**

### J-3 & PA-11 Throttle Cable FAA/PMA Approved



- Throttle Cable .....U12694-002

### Continental Front Prop Plate (Flanged or Tapered crankshaft Installation.)



- Continental Front Prop Plate ....**PC 201** U3991

## Fuel System

### Description Part No.

- Primer .....U451-100  
 Fuel Hose Attach Clamp (PA-11).....454-903  
 Fuel Line Elbow (458-904) **PC 580** AN914-1D  
 PA-11 Fuel Line Elbow  
(460-659) .....**PC 525** 352X6  
 PA-11 Inverted Nut (460-665) **PC 525** 105X2  
 Jet Primer, straight type (PA-11)  
(468-340) .....U31197-000  
 PA-11 Fuel Tank Outlet Nipple  
(476-652) .....**PC 580** AN840-6D  
 Fuel Strainer Screen .....U750-272  
 Fuel Strainer Bowl Seat (KEM type) ....750-273  
 Fuel Tank Cover (PA-11).....U10657-000  
 Fuel Valve to Strainer Line (PA-11)..10729-000  
 Fuel Gauge (PA-11) .....U10804-000  
 Fuel Strainer Bracket Assembly  
(PA-11) .....U71991-000  
 Fuel Tank Finger Strainer.....U72091-000  
 Fuel Strainer Bowl Seat Nut  
(PA-11) .....U72302-003  
 Primer Pump Spacer Bushing  
(PA-11) .....U80012-065  
 Fuel Tank Top Strap Attach Stud  
(PA-11).....U80111-000  
 Fuel Tank Filler Neck Washer .....U80122-048  
 Attaching Clamp (PA-11) .....U80222-003  
 Fuel Tank to Gauge Flex Hose  
(PA-11) .....82371-006

### PA-11 Fuel Gauge Housing FAA/PMA Approved



- PA-11 Fuel Gauge Housing.....U10837-000  
 Float .....U10853-000

**To insure the proper selection of parts, we suggest that you use your J-3 and PA-11 parts manual with this catalog.**

## Fuel System (continued)

### Fuel Drain Items for J-3, J-4, PA-15/17 Fuselage Fuel Tanks with 3/8-inch NPT Drain Boss

- Elbow.....**PC 580** AN915-3D  
 Reducer.....**PC 580** AN912-3D  
 Drain Valve .....**PC 150** 22179-000  
 Plastic Tube (3 ft. required for AD  
85-06-04 priced per ft.)....**PC 150** 189-543

### J-3 12-Gallon Fuel Tank FAA/PMA Approved



- J-3 Fuel Tank.....U70723-000

### J-3 FUEL GAUGE



- J-3 Fuel Gauge.....U71041-000

### J-3 Fuel Valve FAA/PMA Approved



This new valve has a stainless steel ball seated in an inert composite seat. This improved design eliminates the stiff and hard operation.

- .....U70781-000  
 Fuel Valve control cable assembly.....U41471-000

### Piper Gascolator FAA/PMA Approved



- Piper Gascolator.....U14330-002

## Miscellaneous

### Description Part No.

- Fuel Tank Outlet Flex Hose  
(PA-11).....U82371-010  
 1/4-inch Steel U Channel (6-foot  
length) (750-  
284).....X141472  
 3/8-inch Steel U Channel (6-foot  
length) .....U750-285  
 Front Spar Angle Brace, Rear  
(PA-11).....12692-005  
 Rear Spar Angle Brace, Front.....12692-006  
 Rib Cap Repair Splice Strip (12 in.) U16651-004  
 Rib Repair Diagonal Brace  
Repair Section (18 in.).....U750-287-18

**All parts listed are for both J-3 and PA-11, unless otherwise specified.**